

JAKARTA MASS RAPID TRANSIT SYSTEM PROJECT

Phase 1

March 4, 2015



Oriental Consultants Co., Ltd.



**Japan International
Consultants for Transportation
Co., Ltd.**



Pacific Consultants Co., Ltd.



Padeco Co., Ltd.



PT. Inti Era Cipta



PT. Irec Reka Yasa



**PT. Kutami Manajemen
Teknologi**



Pamintori Cipta



**Indotek Engineering
Jaya**



Perentjana Djaja

Table of Contents

1. Project Outline

- 1-1 Project Location
- 1-2 Salient Structures
- 1-3 Typical Cross Section
- 1-4 Railway System and Rolling Stocks

2. Project Progress

- 2-1 Combined Schedule for CP 101 ~ CP 106
- 2-2 Progress photograph

JAKARTA MASS RAPID TRANSIT SYSTEM PROJECT

Phase 1

1. Project Outline



1-1 Project Location (1/3)

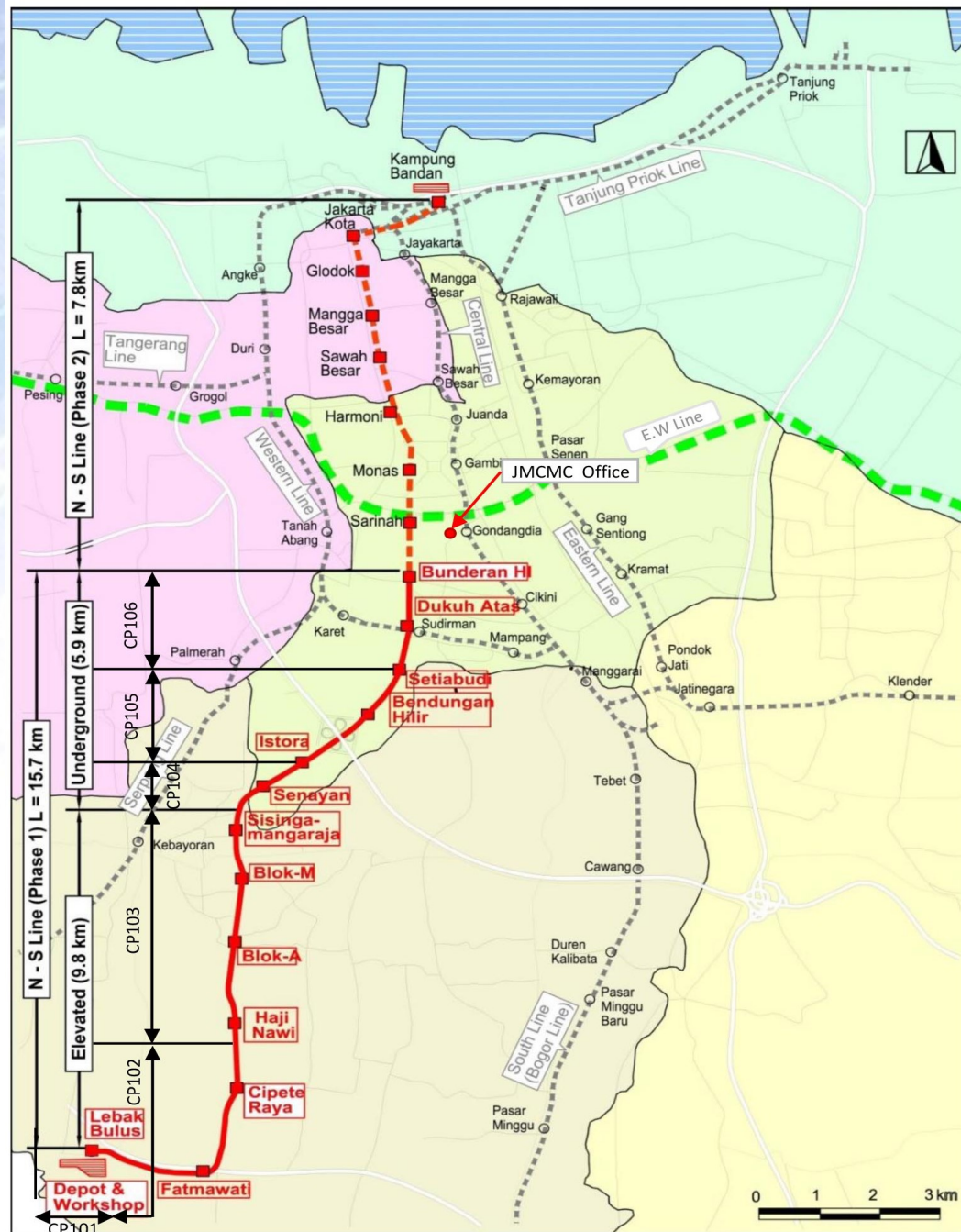

No.	Station Name	Distance(m)	
		Between Platform Centers	Between Station Structures
1	Lebak Bulus		
2	Fatmawati	2018	1843
3	Cipete Raya	1811	1636
4	Haji Nawi	1298	1123
5	Blok A	1217	1042
6	Blok M	1269	1074
7	Sisingamangaraja	629	474
8	Senayan	1536	1332
9	Istora	805	568
10	Bunderan Hilir	1310	1063
11	Setiabudi	765	533
12	Dukung Atas	930	708
13	Bunderan HI *	1054	660

* include crossover structure

1-1 Project Location (2/3)

MRT N-S Phase 1

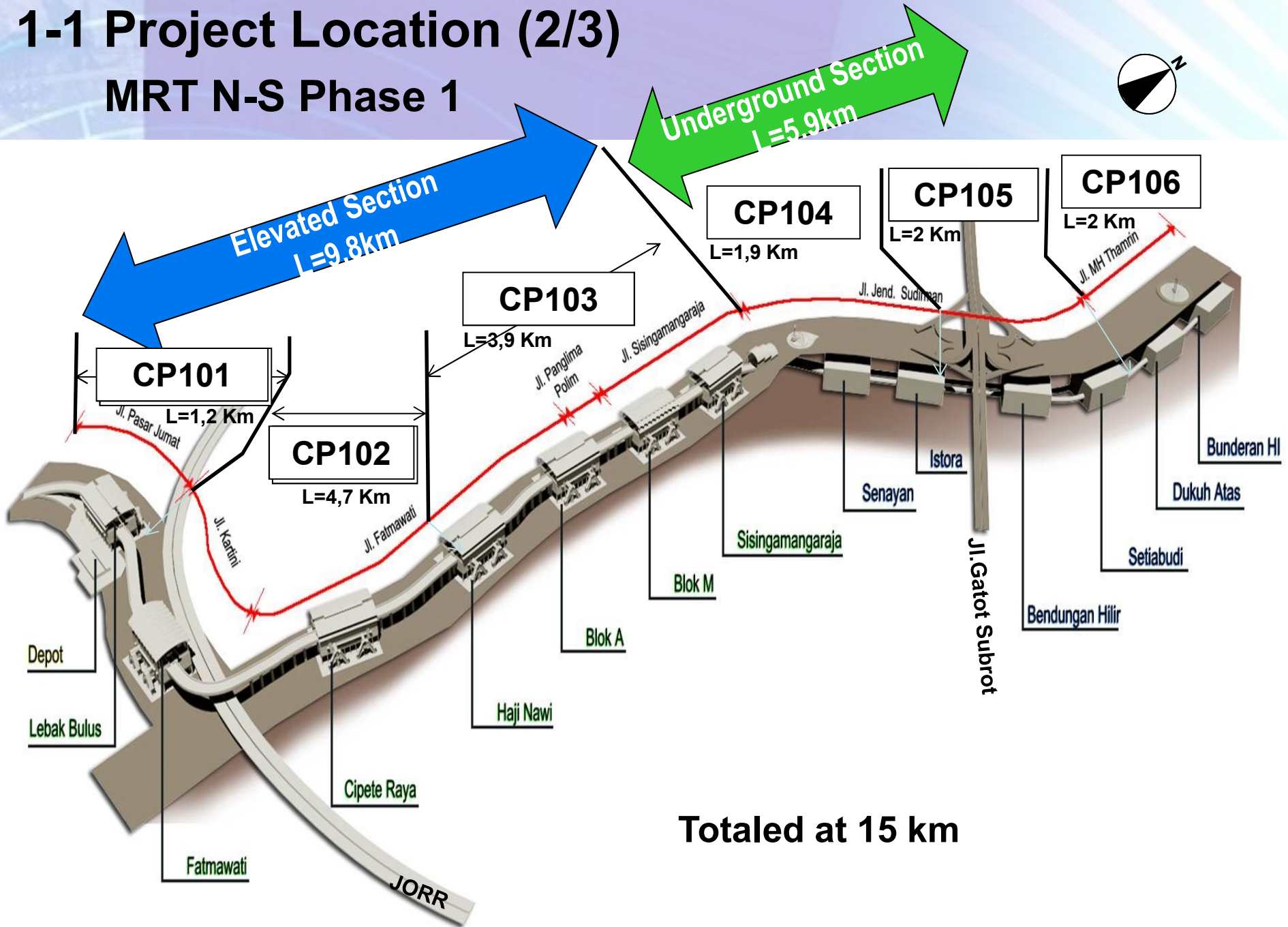

Totaled at 15 km

1-1 Project Location (3/3)

Contract Package

Contract	Works	Contractor	Commencement Date	Duration (weeks)
CP 101	L=1.2km Viaduct, 1 Elevated Station & Depot	Tokyu-Wika	26 Nov 2013	243
CP 102	L=4.7km Viaduct & 2 Elevated Stations	Tokyu-Wika	26 Nov 2013	243
CP 103	L=3.9km Viaduct & 4 Elevated Stations	Obayashi-Shimzu-Jaya	26 Nov 2013	243
CP104	L=1.9km Tunnel & 2 Underground Stations	Shimzu-Obayashi-Jaya	26 Aug 2013	247
CP 105	L=2km Tunnel & 2 Underground Stations	Shimzu-Obayashi-Jaya	26 Aug 2013	247
CP106	L=2km Tunnel & 2 Underground Stations	Sumitomo-Mitsui-HK	26 Aug 2013	247
CP 107	Railway E&M System, Track work	Under Tendering	-	185
CP 108	Rolling Stocks	Under Tendering	Contract signing 03 March 2015	185

1-2 Salient Structures (1/8)

Lebak Bulus Depot & Workshop and Station

Capacity : 14 Train set
18 Tracks (Stabling, workshop, washing, Wheel Turning):

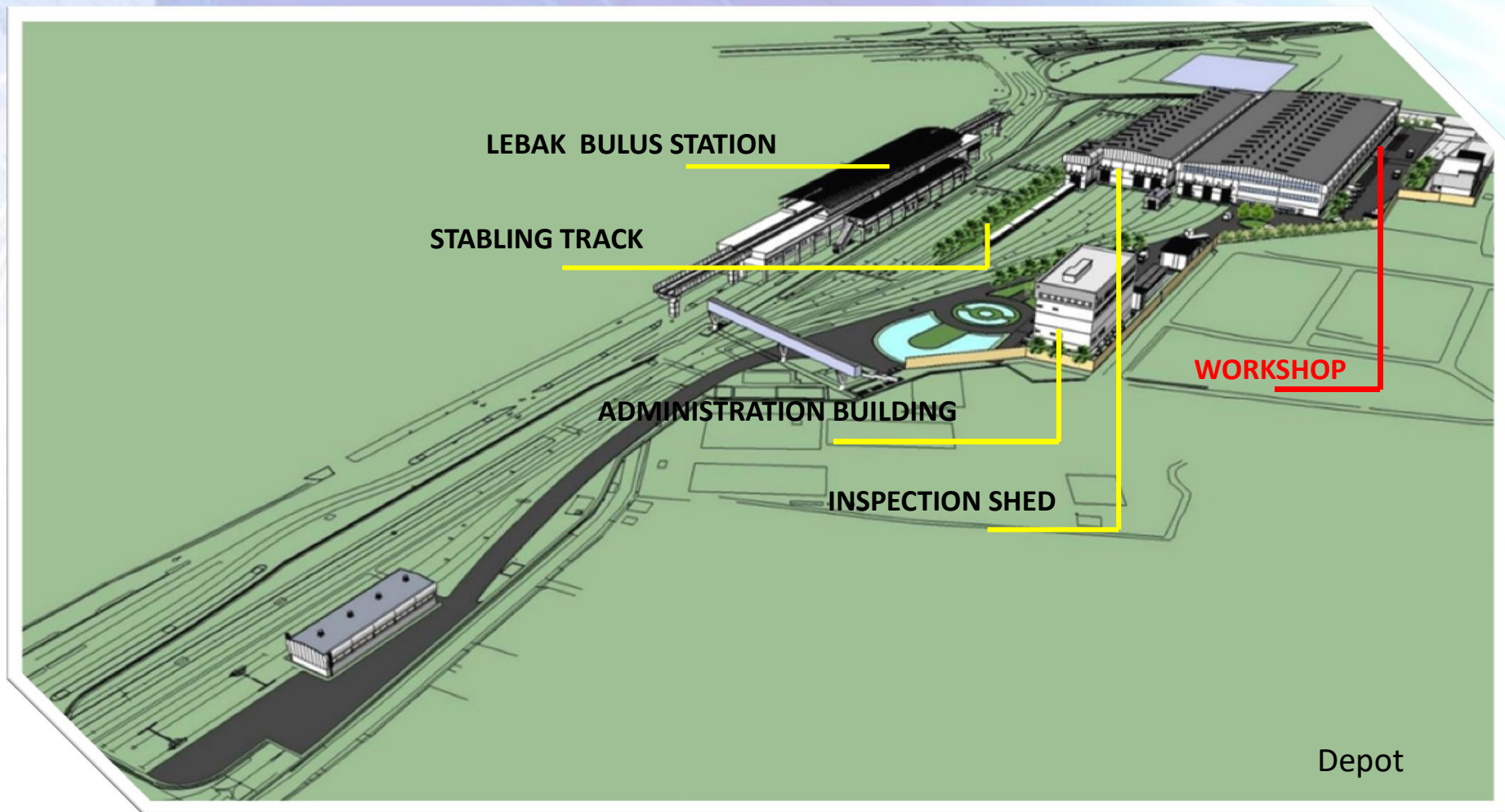

1-2 Salient Structures (2/8)

Overpass Bridge at JORR

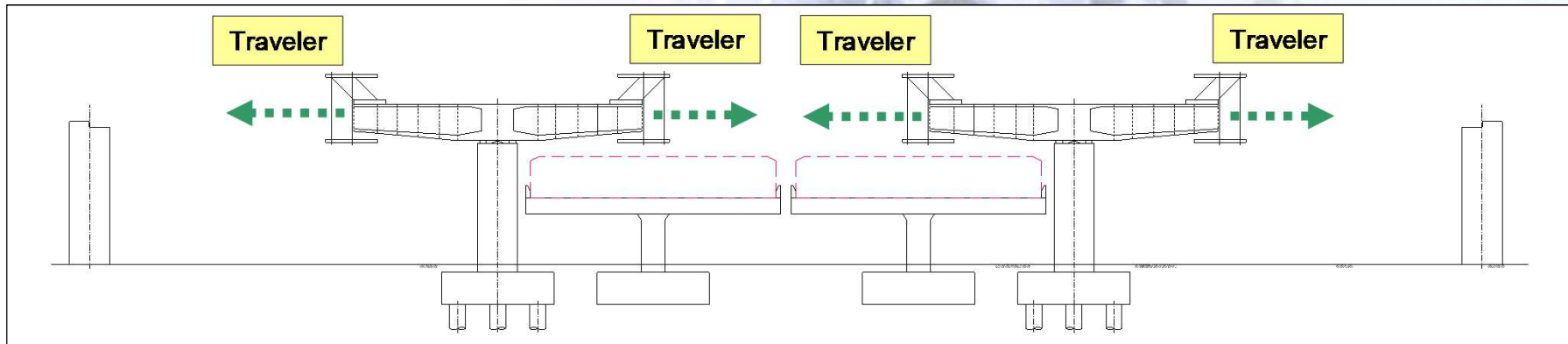

1-2 Salient Structures (3/8) Elevated Structures



Station Exterior



Platform Interior

Blok M Station

1-2 Salient Structures (4/8)

Elevated Structures



Lebak Bulus



Cipete Raya



Fatmawati



Haji Nawati

1-2 Salient Structures (5/8)

Transition Section

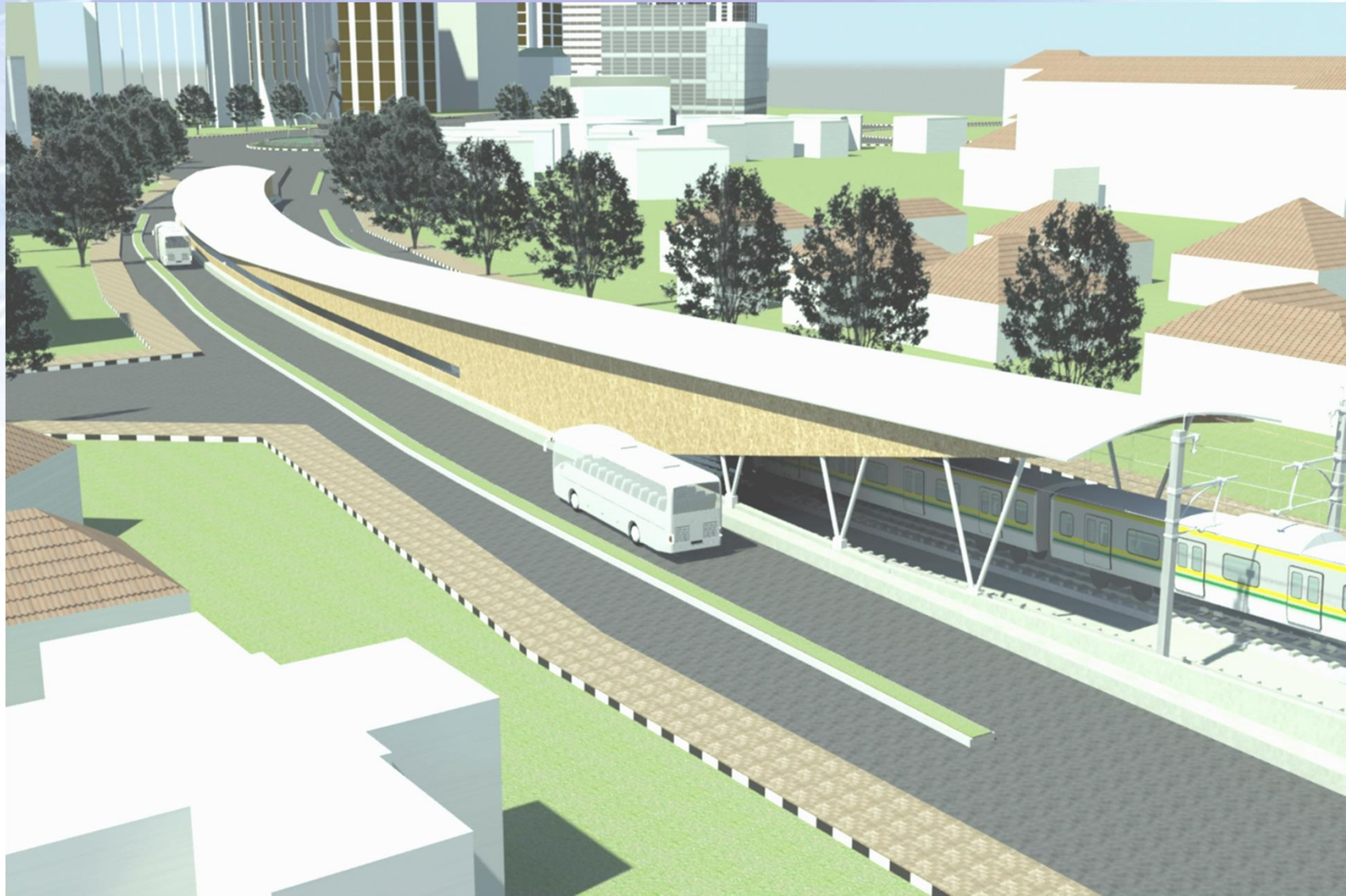

1-2 Salient Structures (6/8)

Double Tube Single Track (DTST)

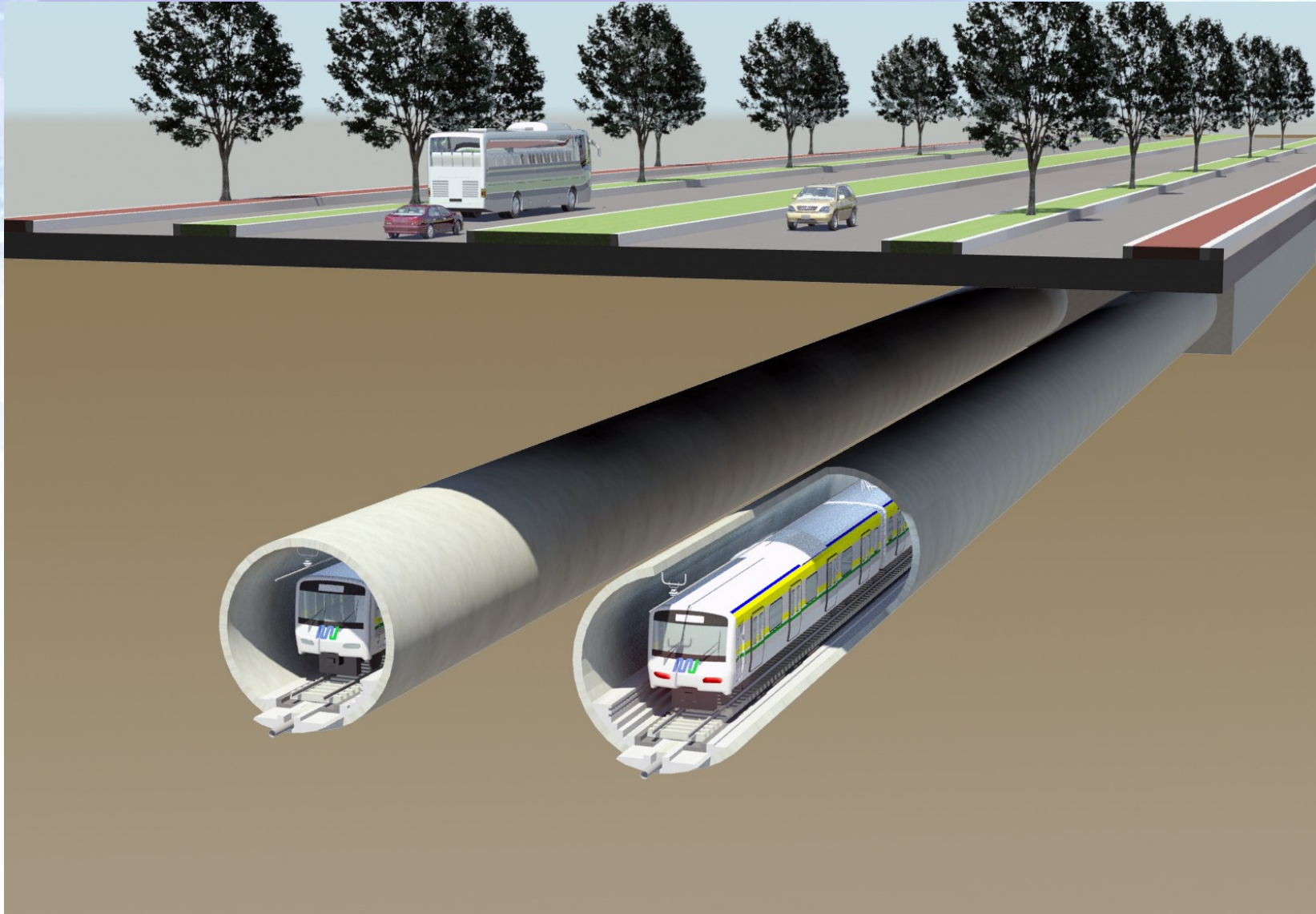

1-2 Salient Structures (7/8) Flooding Protection Measures in Entrance (Elevated Level and Water Stop Plate)



1-2 Salient Structures (8/8) Underground Station



Bunderan HI Station

1-3 Typical Cross Section (1/5) ELEVATED SECTION

Dimension of Elevated Stations

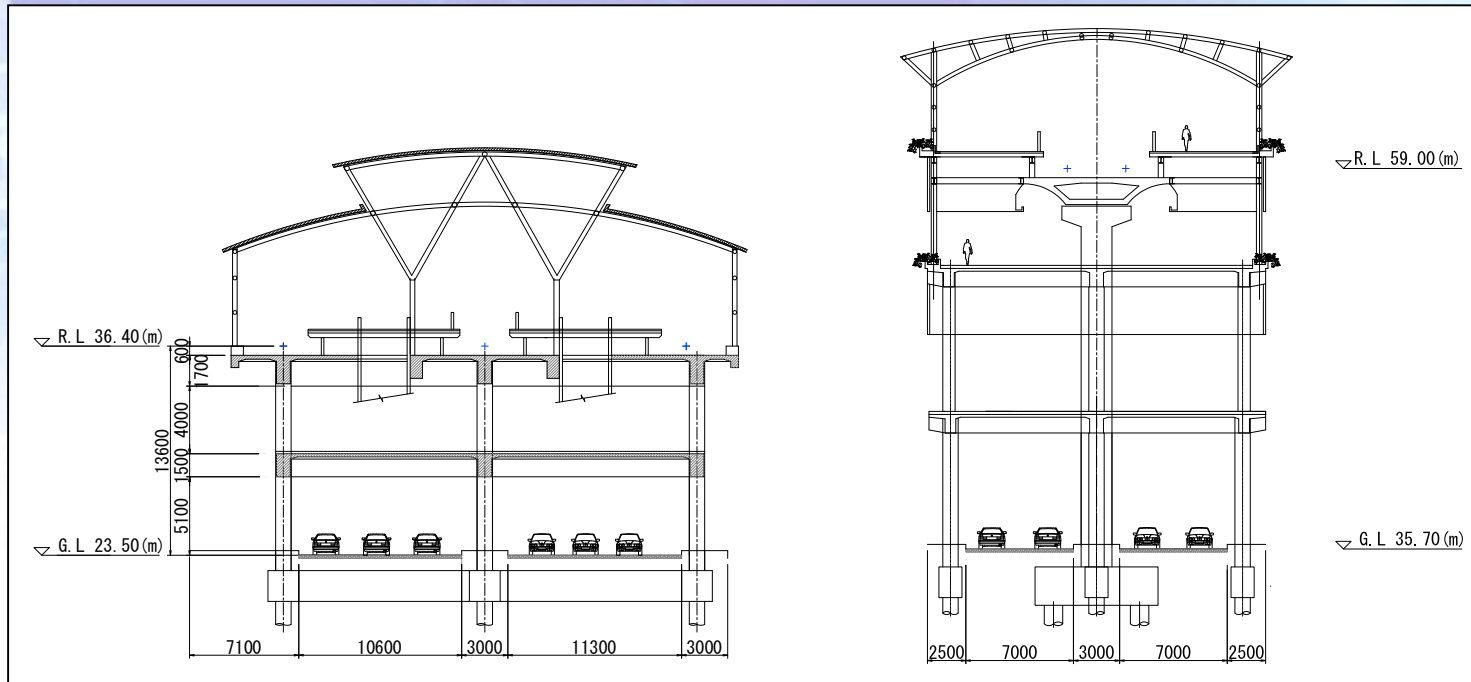

Station	Rail Level (m) (R.L)	Ground Level (m) (G.L)	Height (m) (R.L-G.L)	Height (m) (P.L-GL)	Platform Width (m)	Station Width (m)	Station length out side (m)
Blok M	36.40	23.50	12.90	14.00	9.60	31.00	175
Fatmawati	59.00	35.70	23.30	24.40	7.00	22.00	175

1-3 Typical Cross Section (2/5) ELEVATED SECTION

Dimension of Elevated Stations

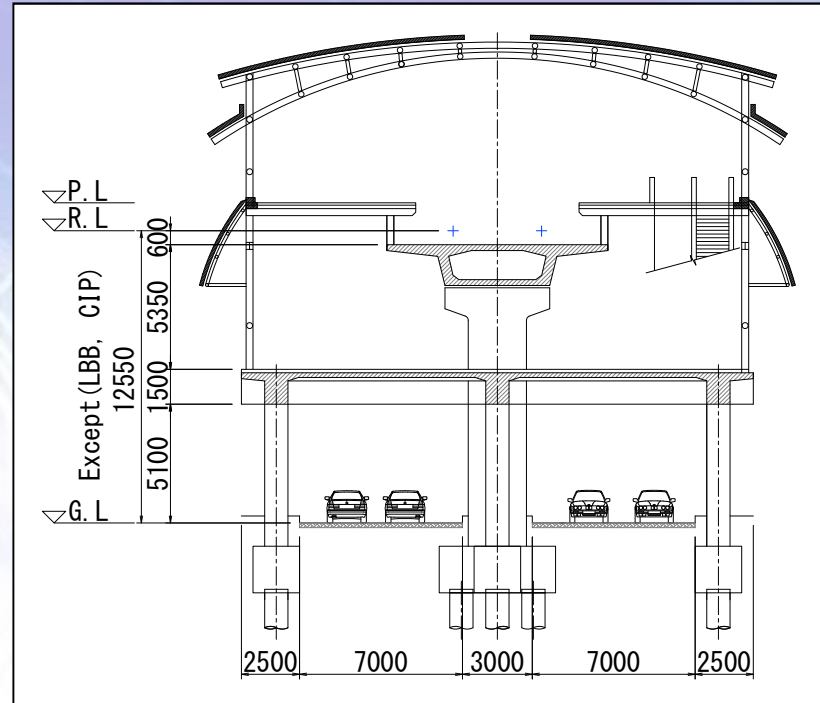

Station	Rail Level (m) (R.L)	Ground Level (m) (G.L)	Height (m) (R.L-G.L)	Height (m) (P.L-GL)	Platform Width (m)	Station Width (m)	Station length out side (m)
Lebak Bulus	50.65	39.60	11.05	12.15	7.00	22.00	200
Cipete Raya	45.30	32.50	12.80	13.90	7.00	22.00	175
Haji Nawari	43.35	30.80	12.55	13.65	7.00	22.00	175
Blok A	41.25	28.70	12.55	13.65	7.00	22.00	175
Sisingamangaraja	35.65	23.10	12.55	13.65	7.00	22.00	175

1-3 Typical Cross Section (3/5) ELEVATED SECTION

Typical Cross Section (Jl. Fatmawati)

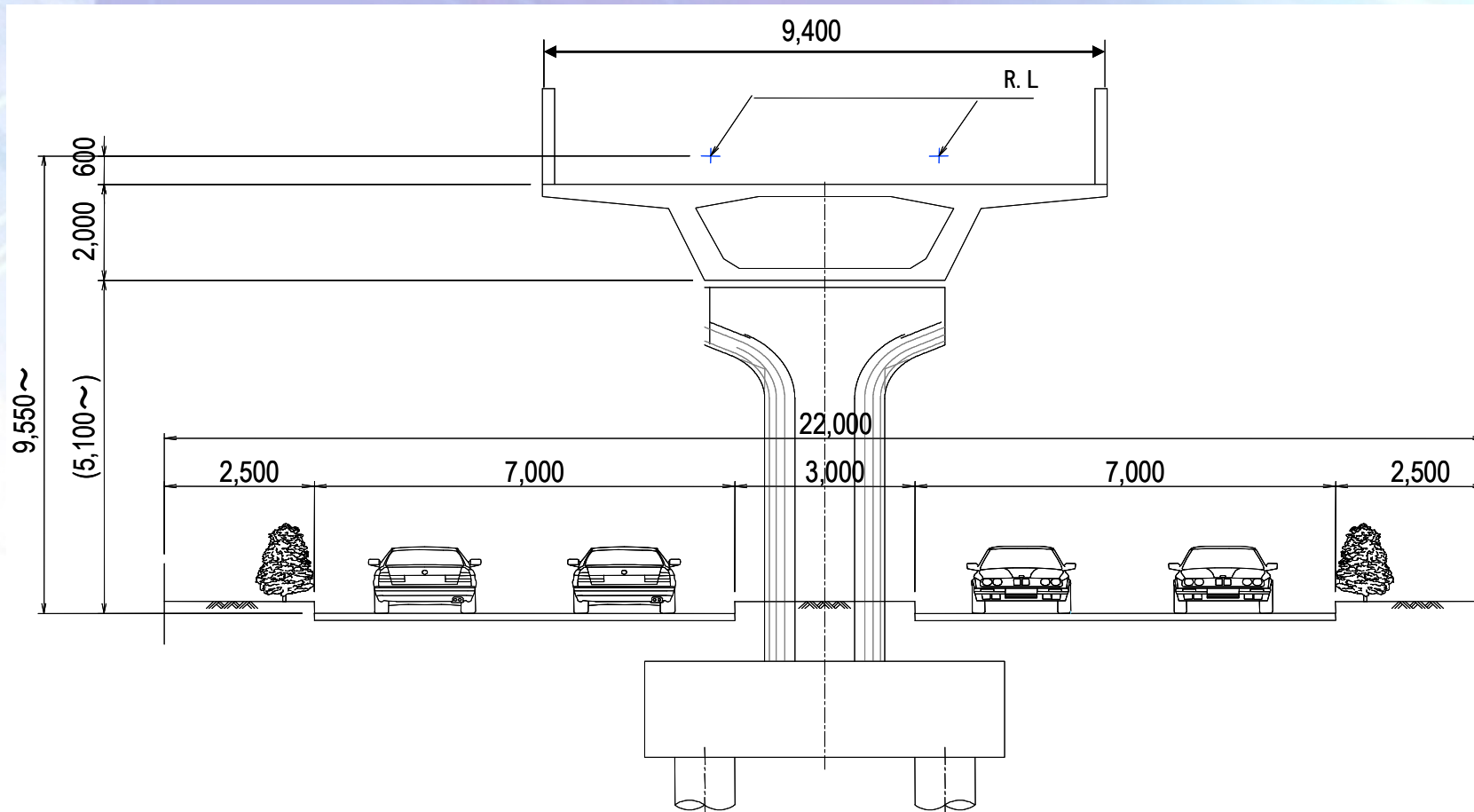

1-3 Typical Cross Section (4/5) UNDERGROUND SECTION

TYPICAL CROSS SECTION OF TUNNEL

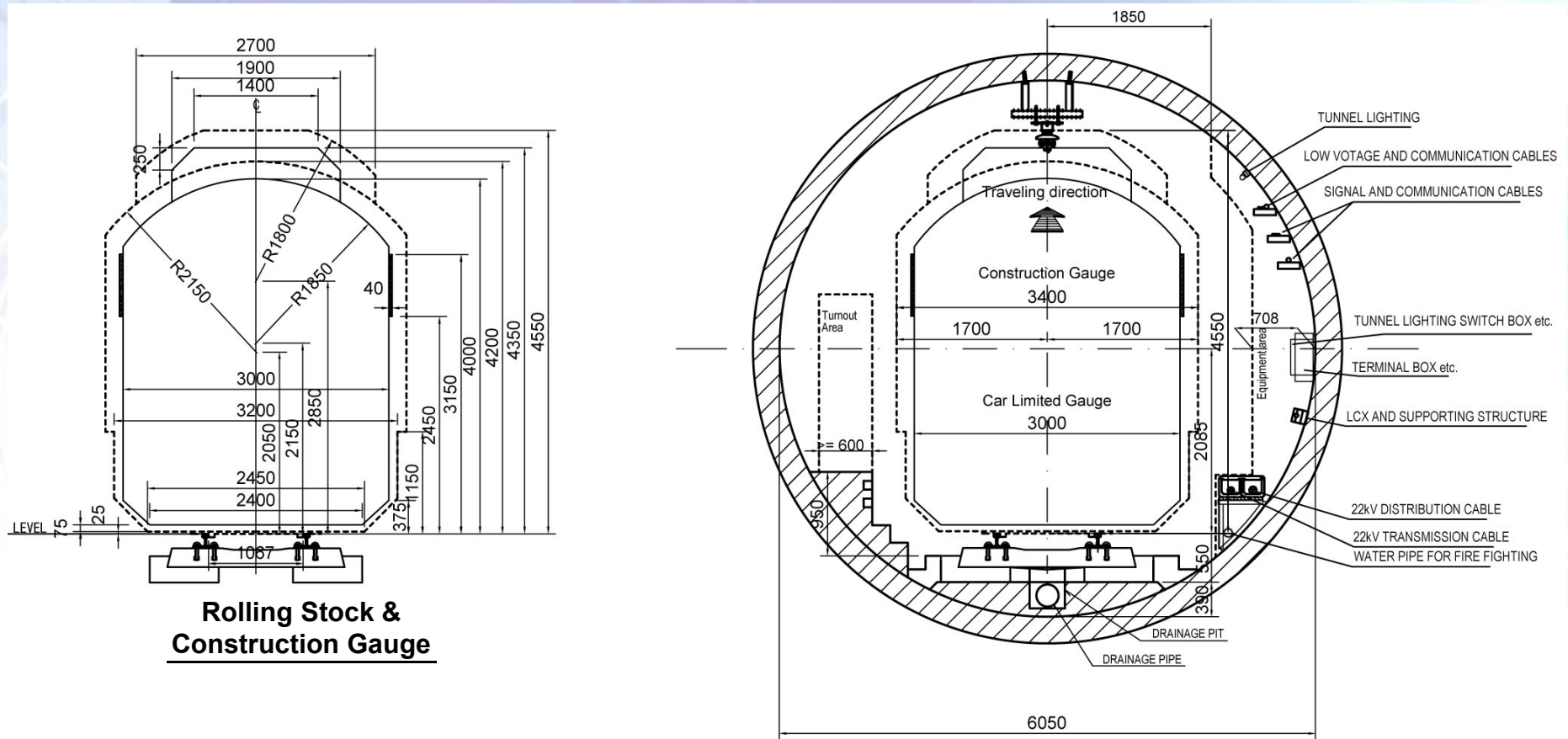

1-3 Typical Cross Section (5/5) UNDERGROUND SECTION

Dimensions of Underground Stations

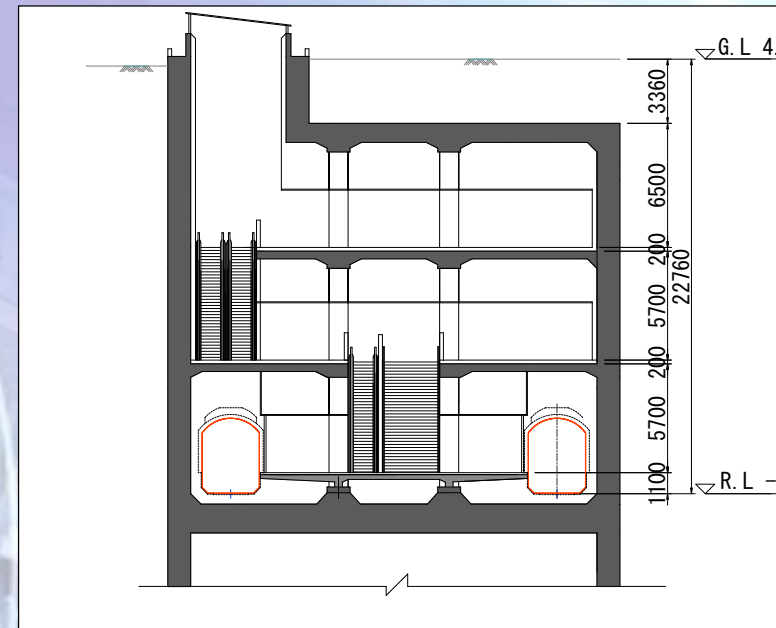
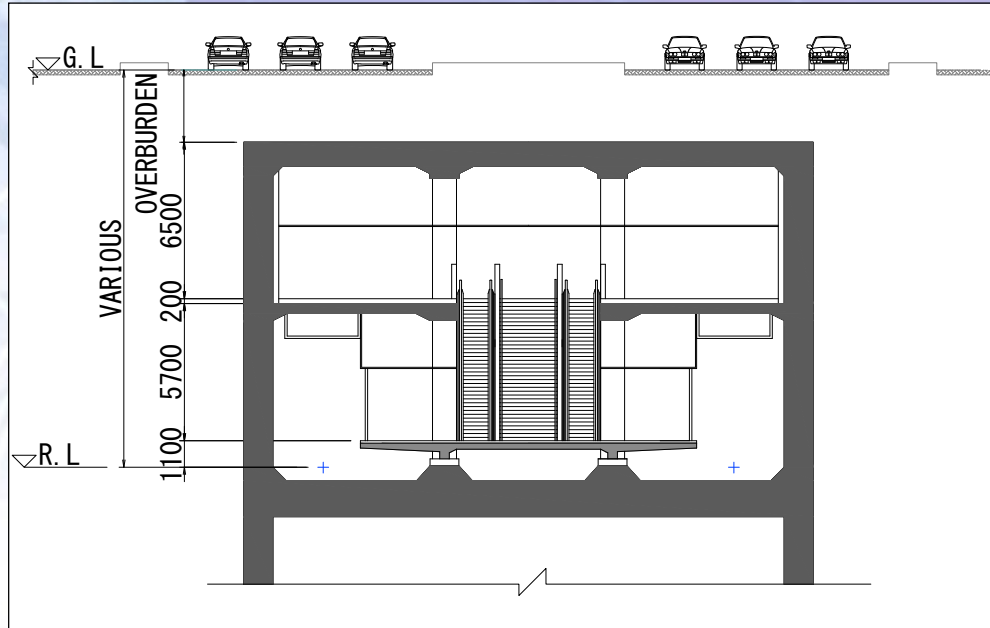

D-wall thickness = 1.0m

Station	Ground Level (m) (G.L)	Height (m) (G.L – R.L)	Rail Level (m) (R.L)	Overburden (m)	Platform Width (m)	Outer Width (m)	Station outer length (m)
Senayan	14.37	15.50	-1.13	2.00	12.00	21.30	232.0
Istora	14.07	16.57	-2.50	3.07	13.00	22.30	252.0
Bendungan Hilir	9.14	17.94	-8.80	4.44	12.00	21.30	232.0
Setiabudi	10.65	16.78	-6.13	3.28	12.00	21.40	232.0
Dukuh Atas	4.38	22.48	-18.10	3.08	12.00	21.30	212.0
Bunderan HI	3.70	16.50	-12.80	3.00	13.00	22.30	252.0

1-4 Railway System and Rolling Stocks (1/7)

ROLLING STOCKS

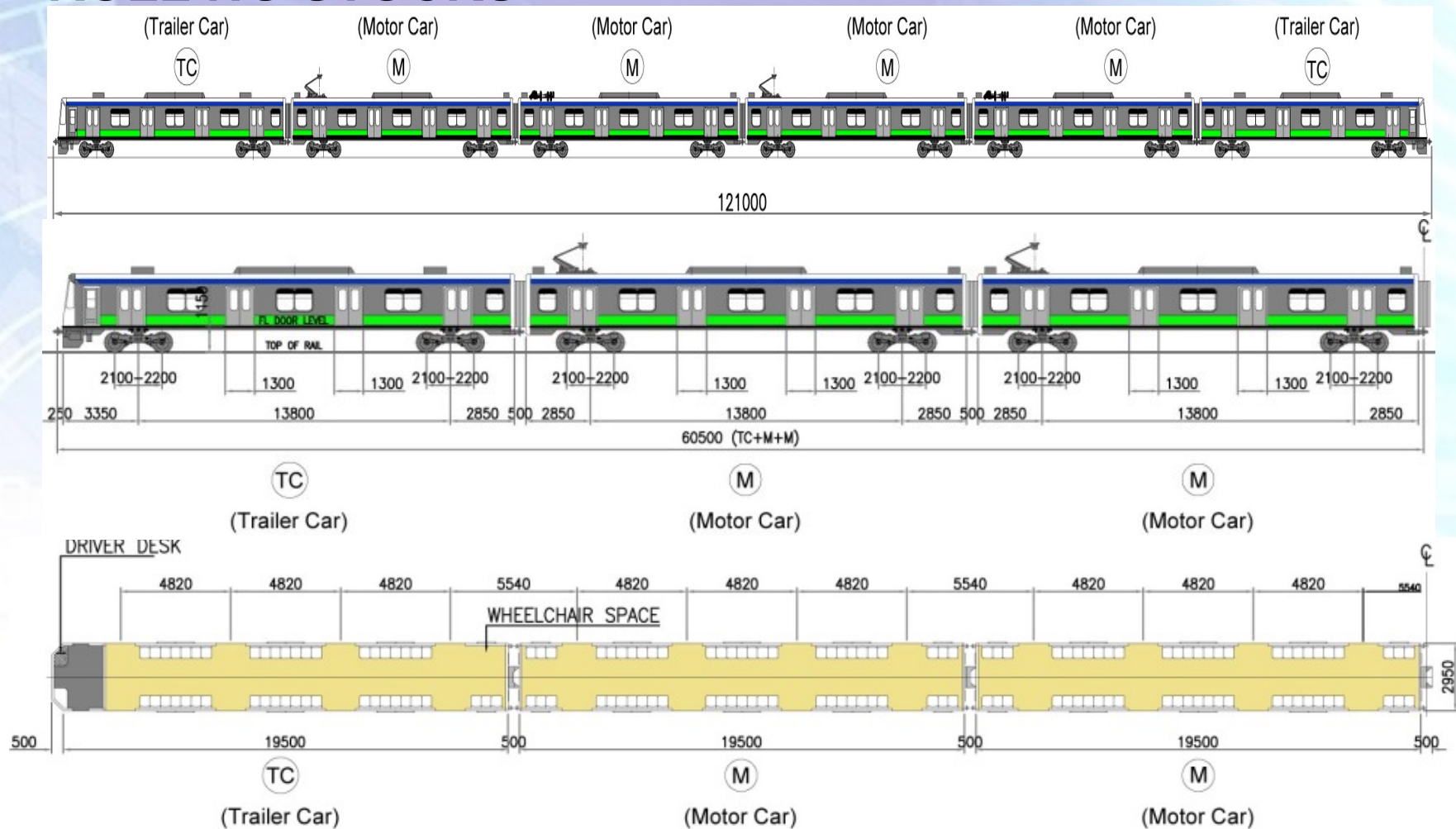

Item	Jakarta MRT
Body Length Over Coupler Face of Leading Car (Tc)	20,500 mm
Body Length Over Coupler face of Intermediate Car (M)	20,000 mm
Body Width	2,950 mm
Roof Height	3,655 mm
Floor Height	1,150 mm

1-4 Railway System and Rolling Stocks (2/7)

Example of ROLLING STOCKS

Tokyo Metro 10000 Series



Tokyo Metro 15000 Series



Tokyo Metro 16000 Series



Tsukuba Express TX-2000



1-4 Railway System and Rolling Stocks (3/7)

SAFETY and One Man Operation

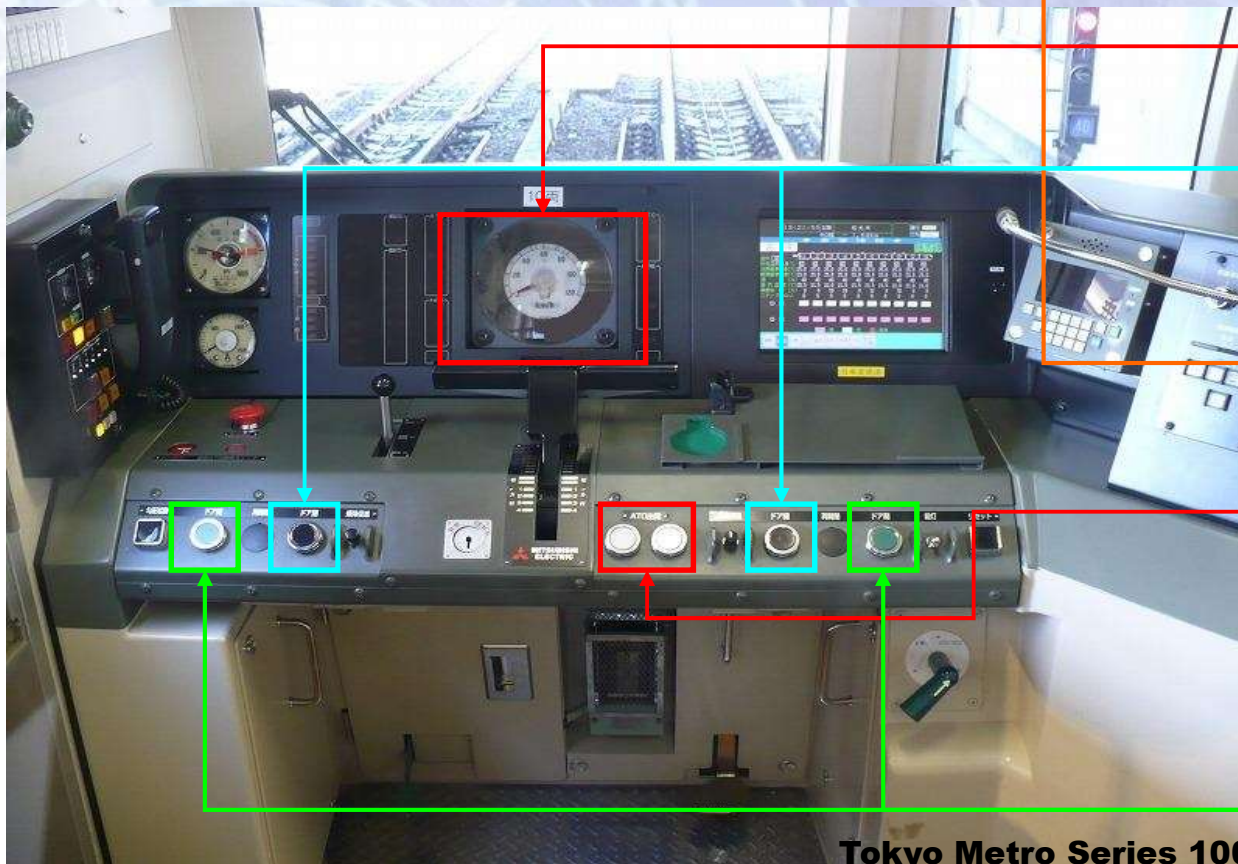

1. Confirmation proceed signal

2. Closing door

3. Confirmation of safety in platform

4. Start button

↓ Automatic drive

5. Confirmation of stopping position

6. Opening door

Tokyo Metro Series 10000

1-4 Railway System and Rolling Stocks (4/7)

Automatic Fare Collection (AFC) System & Signboard (Universal Design)



Flap-door Automatic Gate

Ticket Vending Machine



1-4 Railway System and Rolling Stocks (5/7)

SAFETY with Platform Screen Door (PSD) (High Reliability)



Elevated Station
(Half-height Type)



Underground Station
(Full-height Type)

1-4 Railway System and Rolling Stocks (6/7)

Image of Operation Control Center (OCC)



1-4 Railway System and Rolling Stocks (7/7)

System Configuration

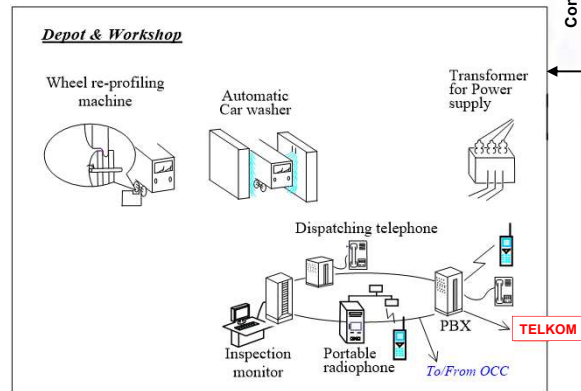
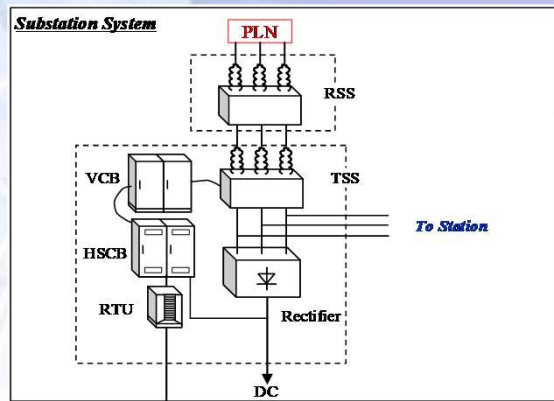

Communication

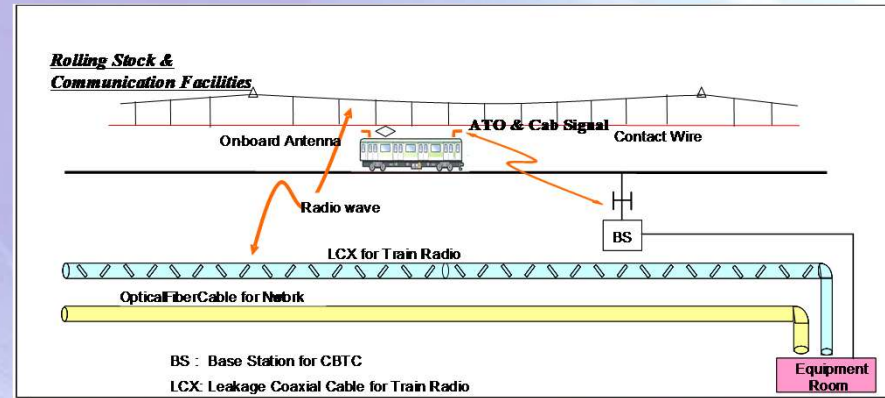

Communication

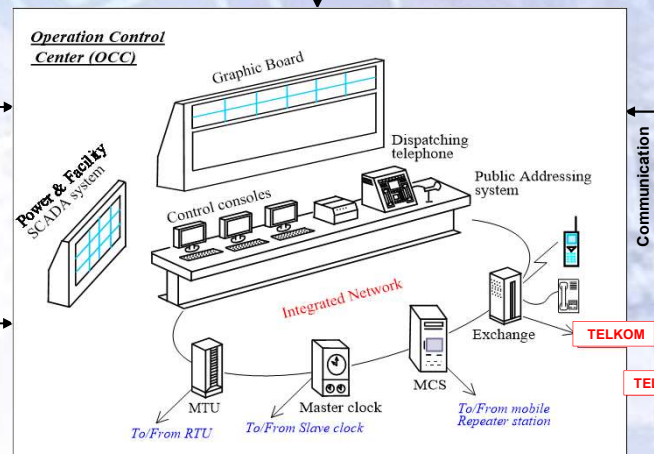

Communication

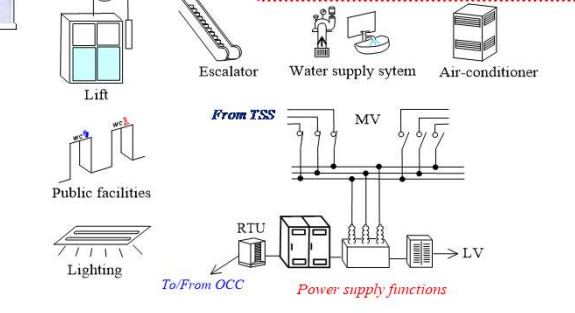
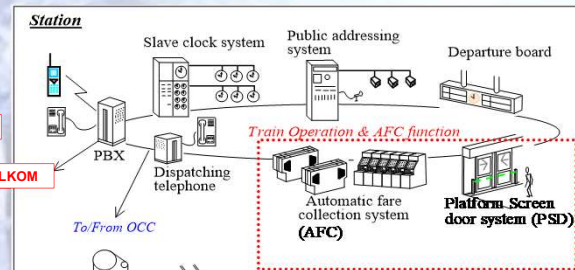
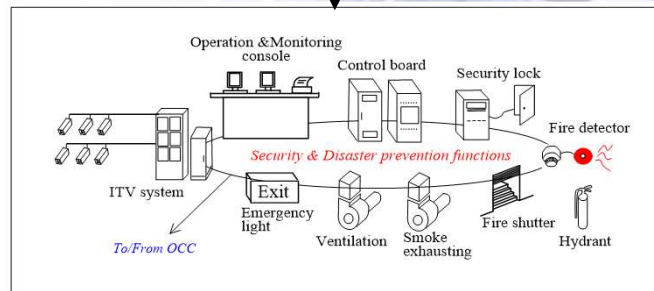

JAKARTA MASS RAPID TRANSIT SYSTEM PROJECT

Phase 1

2. Project Progress



CONSTRUCTION SCHEDULE

Full Services:
July 2018

Trial Run: May 2018

Description	Contractor	Duration		Accumulated Progress up to January		2013				2014				2015				2016				2017				2018			
		Months	Weeks	Plan (%)	Actual (%)	1	2	3	4	1	2	3	4	1	2	3	4	1	2	3	4	1	2	3	4	1	2	3	4
Elevated + Depot	CP 101	TWJO	55,9	243	13,0	5,3				11/13	Actual Progress				Elevated Design & Construction												07/18		
Elevated	CP 102		55,9	243	18,8	6,6				11/13	Actual Progress				Elevated Design & Construction												07/18		
	CP 103	OSJ	55,9	243	23,0	10,6				11/13	Actual Progress				Elevated Design & Construction												07/18		
Underground	CP 104	SOWJ	56,9	247	42,5	20,6			08/13	Actual Progress				Underground Design & Construction												05/18			
	CP 105		56,9	247	38,9	19,3			08/13	Actual Progress				Underground Design & Construction												05/18			
		CP 106	SMCC	56,9	247	19,3	19,4			08/13	Actual Progress				Underground Design & Construction												05/18		
Railway System & Trackwork	CP 107	not yet	42,6	185	-	-								01/15	Design, Procurement & Installation												07/18		
Rolling Stock	CP 108	not yet	42,6	185	-	-								01/15	Design & Procurement												07/18		
Integration Testing & Commissioning	-	-	4,2	18	-	-									Up to January												12/17	04/18	
Trial Run	-	-	2,8	12	-	-																					05/18	07/18	
TOTAL					24,9	13,1																							

█ Elevated
 █ Depot
 █ Underground
 █ Railway System
 █ Rolling Stock
 █ Actual Progress
 XX/YY = Month/Year

PROGRESS OF WORK (Period : up to 25th January 2015)

CONTRACT PACKAGE	CONTRACTOR	Akumulasi Kemajuan Konstruksi per Januari 2015			
		PLAN (%)	ACTUAL (%)	Deviation(%)	
DEPOT & ELEVATED	CP101	TWJO	13.06	5.28	(7.78)
	CP102		18.75	6.56	(12.19)
	CP103	OSJ	23.01	10.56	(12.45)
UNDER GROUND	CP 104	SOWJ	42,74	20,64	(22,10)
	CP 105		38,89	19,27	(19,62)
	CP 106	SMCC-HK	19,35	19,39	0,04
TOTAL			24,90	13,09	(11,81)

Estimated Project Delay and Matter of Concerns as of Jan 2015

Contract Package	Project Delay (as of Jan 2015)		Major Reason of Delay	Matter of Concerns (as of Jan 2015)
		EOT Evaluated by the Engineer		
CP101		Estimated to be 6.0 months (under evaluation) ^{Note1}	Land Acquisition	Construction work of workshop will be delayed for 6.0 months due to land acquisition procedure
CP102		Estimated to be 5.0 months (under evaluation) ^{Note1}	Land Acquisition	Land acquisition around the Cipete Raya st. (not yet confirmed)
CP103		Estimated to be 2.5 months (under evaluation) ^{Note1}	Design Change Utility Relocation	Land acquisition around the Haji Nawir st. (not yet confirmed)
CP104		4.2 months	Utility Relocation (Water Supply Pipe)	Construction work will be delayed for 4.2 months .
CP105		4.2 months	Utility Relocation (Water Supply Pipe)	Construction work will be delayed for 4.2 months .
CP106		Estimated to be 1.0 month (under evaluation)	Utility Relocation (PLN Substation)	
CP107		-	Delay of civil work	Commencement day will be delayed for 5.0 months .
CP108		-	Delay of civil work	Commencement day will be delayed for 5.0 months .

2-2 Progress Photograph (1/5) From Lebak Bulus to JORR Overpass Bridge (CP101 – CP102)

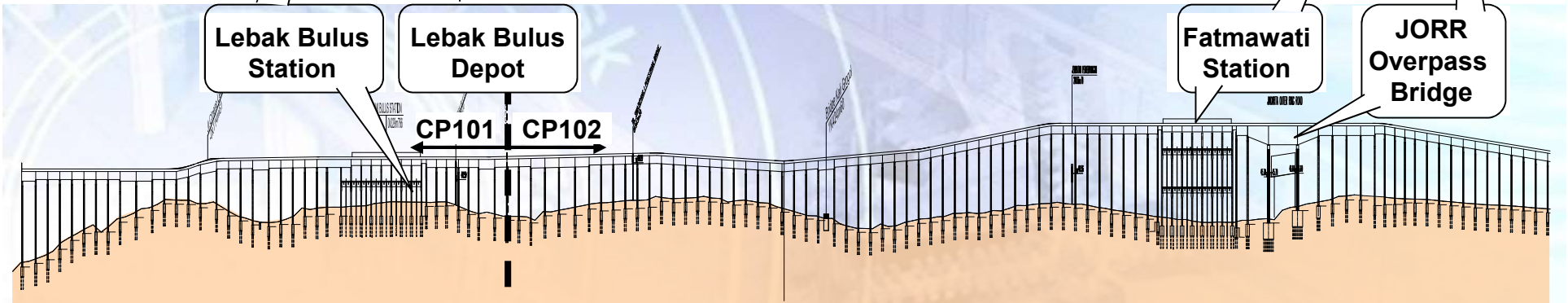
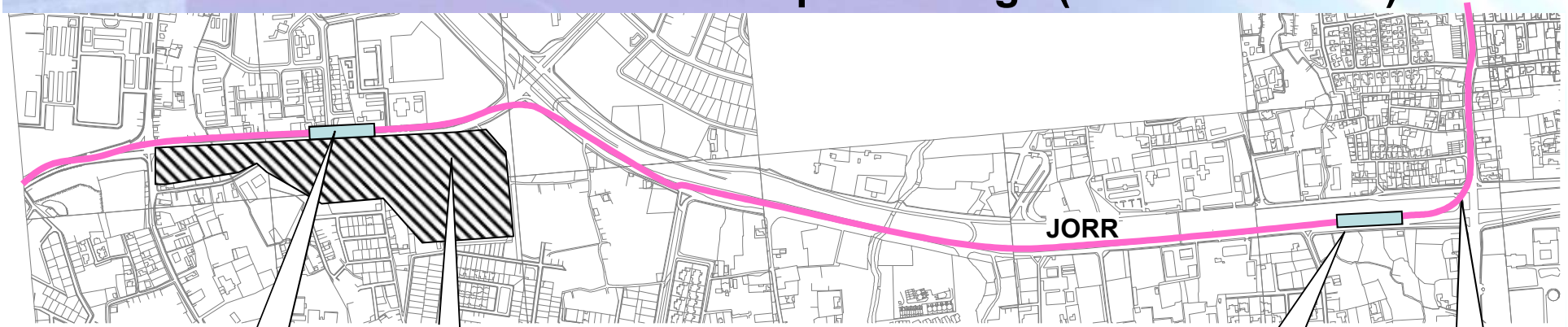

LBBT: Box Culvert Section B&D pouring concrete finished



West Side Depot Area : PDA Test



JI. TB Simatupang: Point Square LP 7 and LP 8 Permanent Pile

2-2 Progress Photograph (2/5) From Cipete Raya to Blok A (CP102 – CP103)

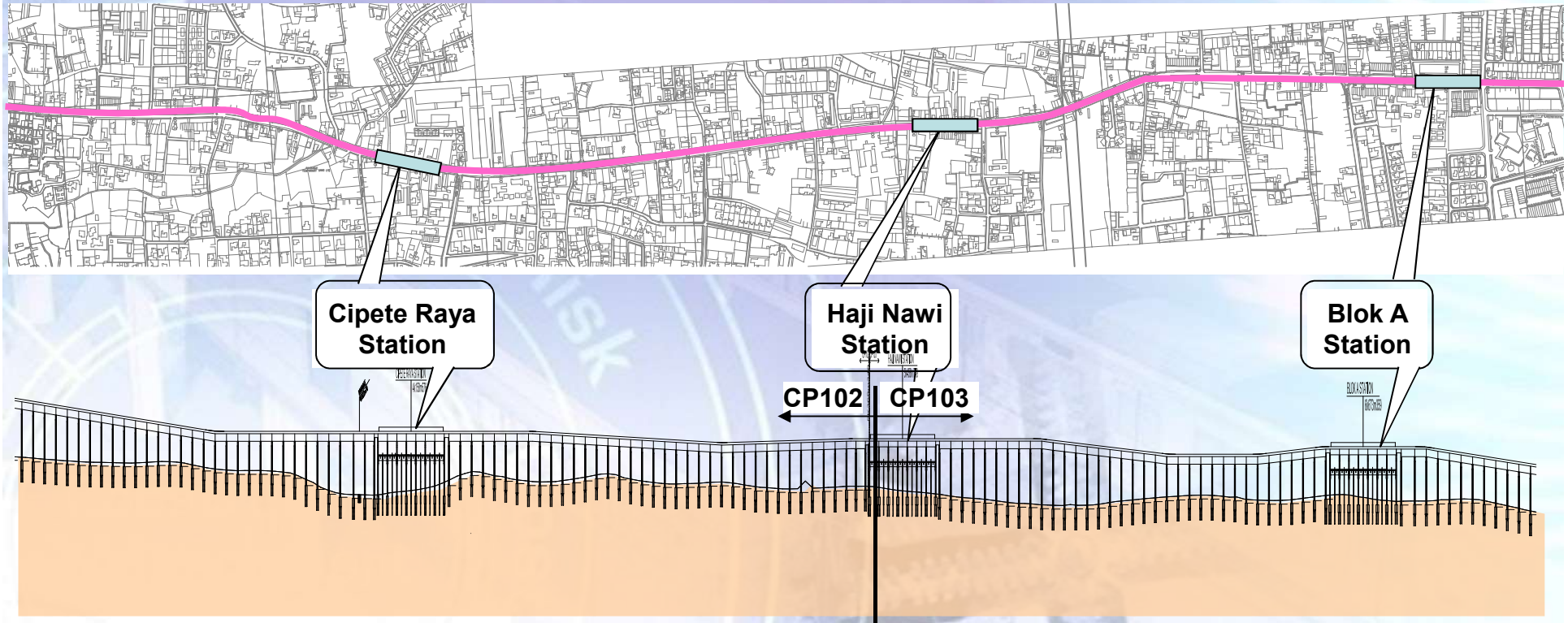

Jl. Fatmawati, FP-16 to FP-30 Barricade was installed



Haji Nawi Station : Reinstatement of Utility Excavation Required



Blok A Station : Waste Cleaning Required

2-2 Progress Photograph (3/5) From Blok M to Transition Section (CP103 – CP104)

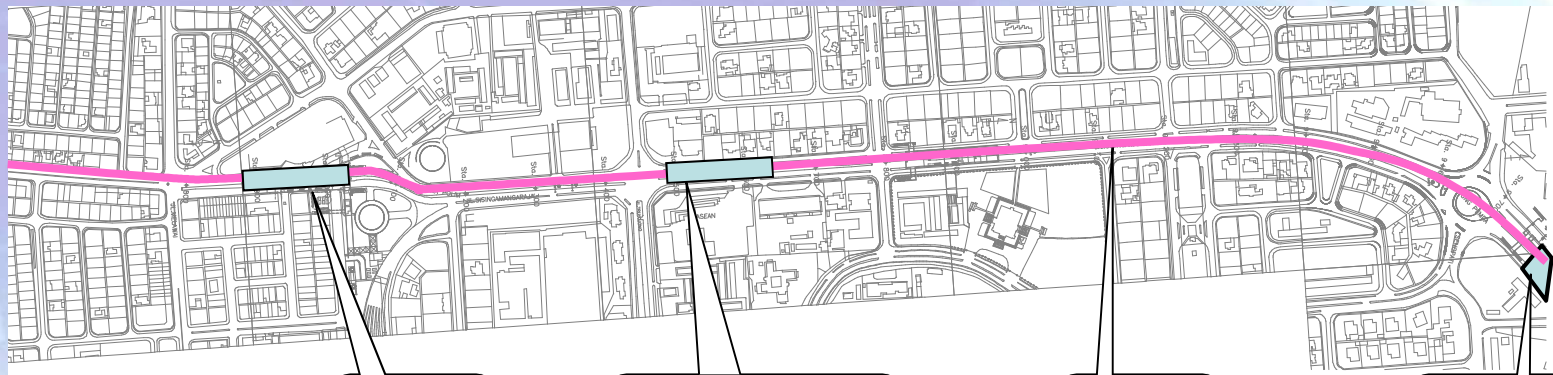

Blok M Station

Sisingamangaraja Station

Transition Section

Senayan Station

← CP103 CP104 →



**Blok M (Center Median) :
Pilling MS 11 C No Pile 4**



**Sisingamangaraja (West Side Front
Kejaksanaan Agung MP12) : Boring Fly
Over Busway Project**



**Transition Area:
Soil Excavation layer 2 at zone 2**

2-2 Progress Photograph (4/5) From Senayan to Bendungan Hilir (CP104 – CP105)

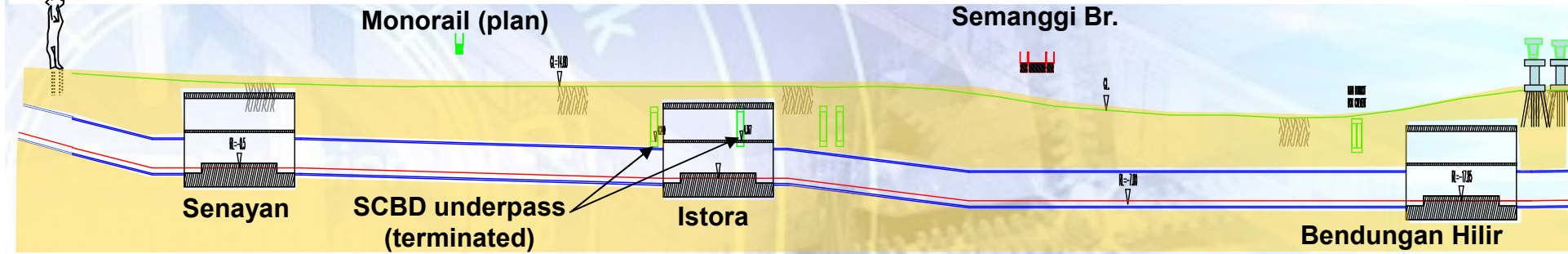
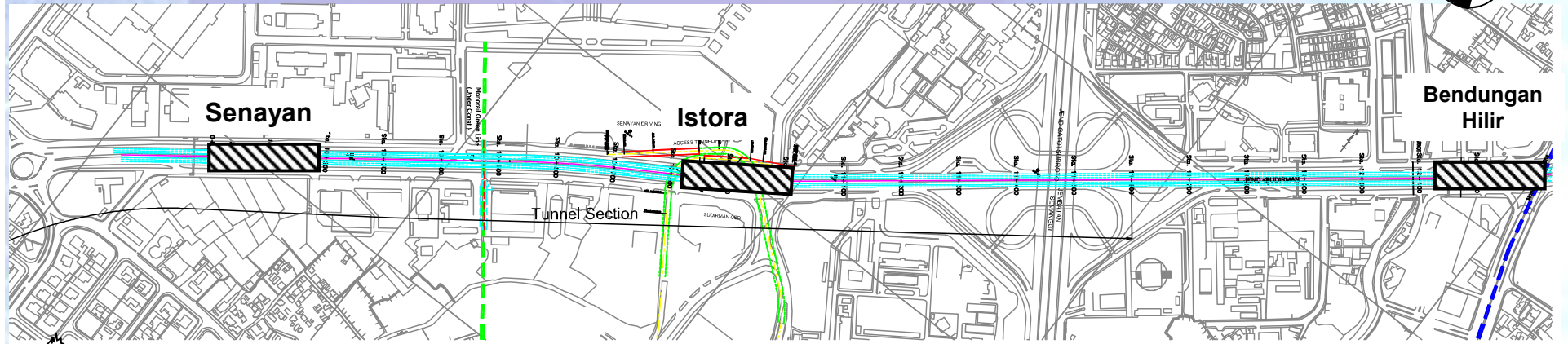

Senayan Station :
Drilling Kingpost



Istora Station :
Pouring Concrete D-wall P76

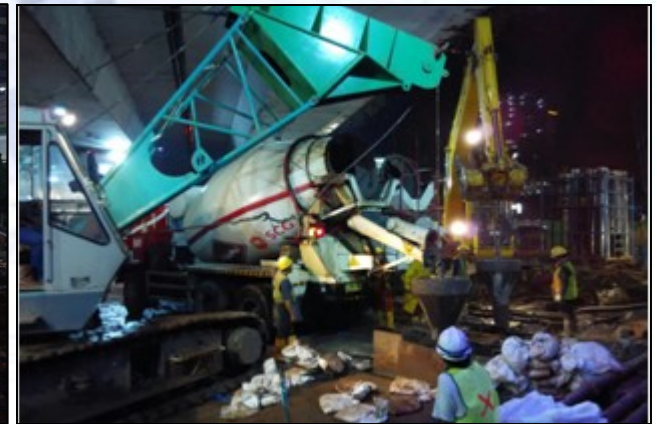

Bendungan Hilir Station :
Pouring concrete (casting) for Dwall
no P34 under Karet FO

2-2 Progress Photograph (5/5) From Setiabudi to Bunderan HI (CP 105 – CP106)

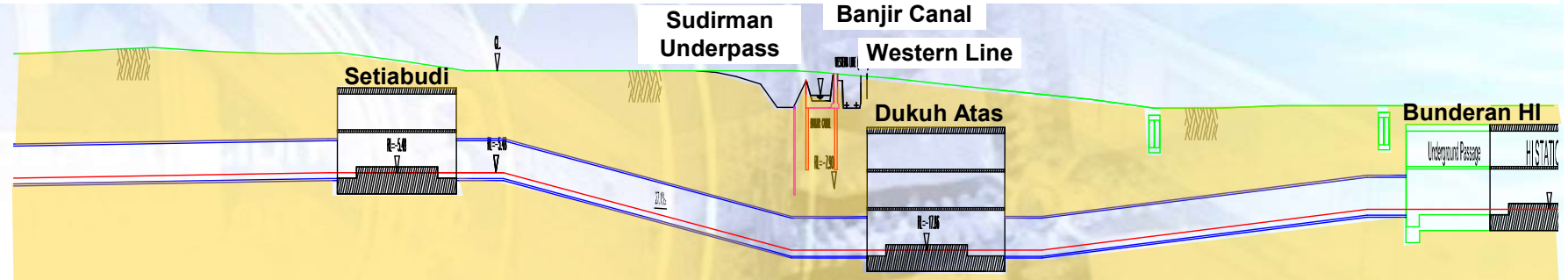
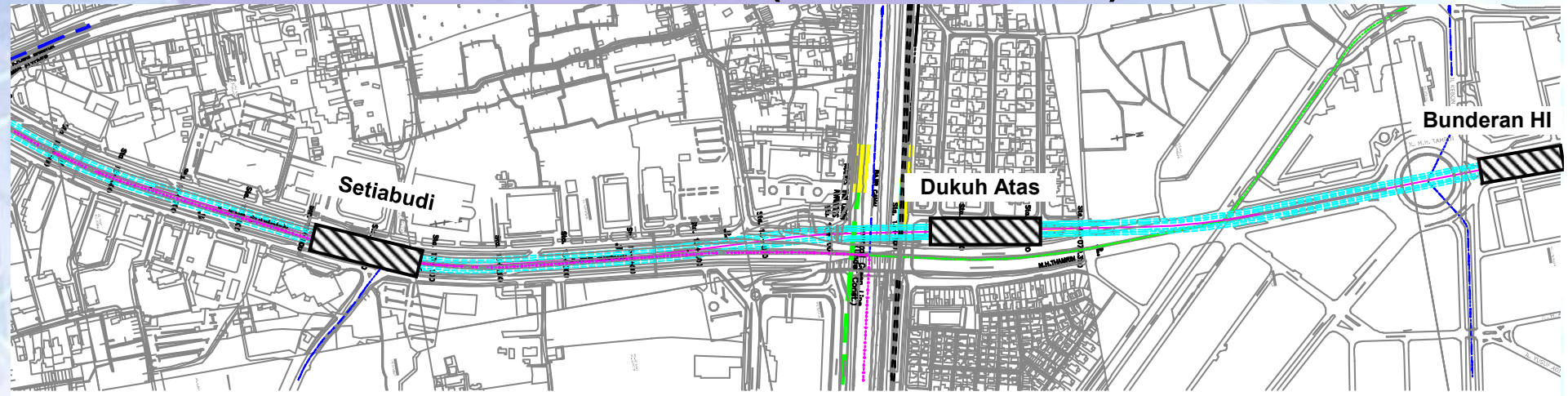

Setiabudi Station : D-wall panel no P30 under pouring concrete at east side



Dukuh Atas Station: Soil Improvement



Bunderan HI Station : Tremie Pipe Installation for D-Wall34

TERIMA KASIH

THANK YOU

